

Клавиатура для PTZ видеокамер

РУКОВОДСТВО

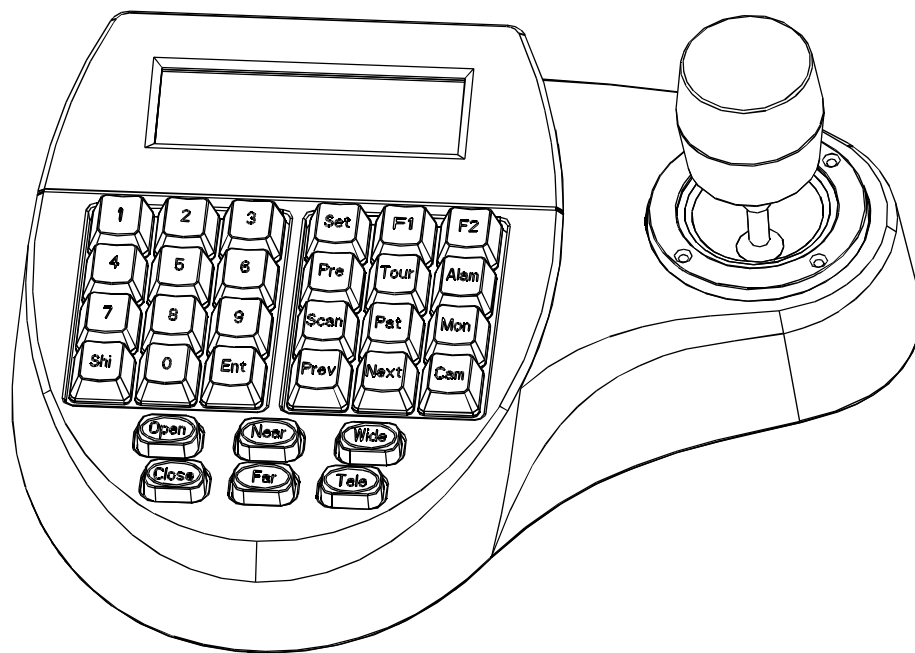

CATALOGUE

1. Summary-----	1
1.1 Notice-----	1
1.2 Function and Characteristic-----	1
1.3 Technical Data-----	1
2. Keyboard Connection-----	2
2.1 Keyboard Interface Instruction-----	2
2.1.1 Rs422 and Rs485-----	2
2.1.2 RJ45 Interface-----	2
2.3 Matrix Connection-----	3
2.3.1 RJ45 Local Connection-----	3
2.3.2 RS422 Remote Connection-----	3
2.4 Connect with The Dome Directly-----	4
2.5 The Connection of The Keyboard in The System-----	5
3. Keyboard operation manual-----	6
3.1 Current-carrying to keyboard-----	6
3.2 LCD-----	6
3.3 Joystick controls dome -----	6
3.4 Change object dome-----	7
3.5 Control dome lens-----	7
3.6 Set dome function-----	7
3.6.1 Preset-----	7
3.6.2 Scan-----	7
3.6.3 Pattern-----	8
3.6.4 Tour-----	8
3.7 Call dome main menu-----	8
3.8 Control matrix-----	8
3.8.1 Switch dome in order-----	8
3.8.2 Call matrix main menu-----	8
3.8.3 Confirm after program-----	8
3.8.4 Change object monitor-----	8
4. Keyboard control-----	9
4.1 keyboard index setting-----	9
4.1.1 Set ID number-----	9
4.1.2 Set the baud rate-----	9
4.1.3 Joystick calibration-----	10
4.1.4 Multi keyboard state-----	10
4.1.5 Keyboard message display-----	10
4.2 Dome setting-----	10
4.2.1 Dome preset setting-----	11
4.2.2 Dome scan setting-----	11
4.2.3 Dome pattern setting-----	12
4.2.4 Dome tour setting-----	12
4.3 Protocol setting-----	12
4.3.1 Pelco matrix model-----	13
4.3.2 Dome controlling mode-----	13
4.4 Exit keyboard menu-----	13
5. Appendix-----	14
5.1 Rs485 Bus Basic Knowledge-----	14
5.2 Keyboard shortcut operation manual-----	15
6. Keyboard Menu Index-----	16
7. Maintenance-----	17

1. Введение

The keyboard is an universal keyboard of security monitoring series, which can control integrate dome camera with all kinds of protocols matrix and DVR , which has been equipped with 3D joystick and 2D joystick which can control the revolving of the camera and the zoom magnification of lens; with the LCD screen and the function of back-light; which can display the current operation order、 the control protocol name、 the current dome ID、 the current monitor ID and the state of joysticks . The user can control the CCTV system more easily with the joystick and the LCD screen .

1.1 Notice

- Please read the manual carefully and reserve it.
- Please advert to the notice in manual.
- Please don't place the keyboard in the moist place.
- Please don't close up the keyboard to exothermic object for long time.

1.2 Функционал

- Rs485шина для соединения с31 камерой в режиме непосредственного управления
- Совместимость с протоколами Pelco D и P.
- Изменение Диафрагмы,Фокуса и Зума.
- You can set and call the preset, run scan、 pattern and tour.
- You can control the matrix and through which can control the dome indirectly.
- It has been equipped with the 2D/3D joystick and the larger LCD screen.



1.3 Технические параметры

- ◆ Электрические параметры
Напряжение: 9В-12В DC
Мощность: 2.5Вт
- ◆ Соединения
Интерфейсы:
RS485×1, RS422×1
Частота связи :
2400 ,4800, 9600、 19200Bps
- ◆ Допустимая дистанция:
1.2 км (RS485 и Rs422 позволяют достичь этого)
- ◆ Окружающая среда
Температура: 0~50℃
Влажность: до 90%
- ◆ L*W*H=218*180*55 (mm)
Weight: 630g (NetWeight)

2. Соединения

2.1 Клавиатурные интерфейсы

На задней панели клавиатуры имеется интерфейс, оснащенный различными коммуникационными интерфейсами: RS485, RS422 (опция), RJ45(опция), которые позволяют подключать и контролировать различные виды периферийного оборудования.

2.1.1 RS485 интерфейс

Rs485-интерфейс 6-битного кабеля.

RS485 содержит клеммы А и В; + -
где RS485 А- положительный полюс,
В- отрицательный полюс

2.1.2 RJ-45 интерфейс (опция)

Это стандартный сетевой интерфейс (при наличии), который в основном можно использовать для подключения к матрице на небольшом расстоянии (расстояние менее 7,6 м). Подробности см. в разделе 2.3 «Подключение камеры».



Рис.2-1.1



Рис.2-1.2

6Bit шина RJ45 Питание DJK11

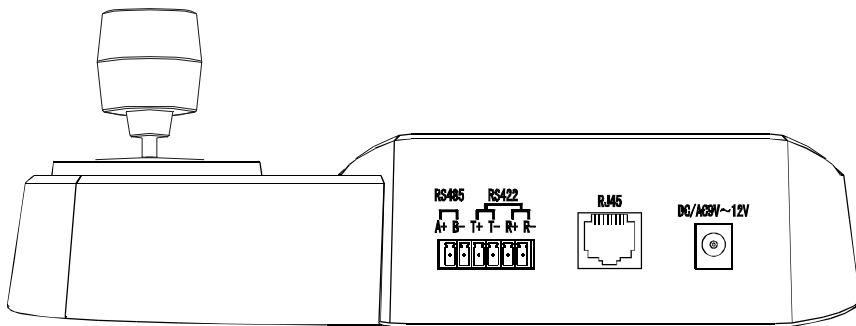
2. 2 Matrix Connection

The keyboard can control matrix of PELCO CM6700、CM6800.For example (following) that the keyboard connects with the PELCO CM6700 matrix in order to introduce the connection between the keyboard and the matrix.

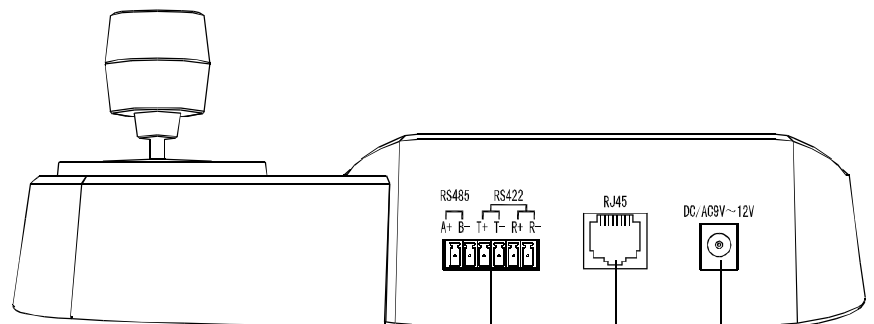
There are two kinds of keyboard connection interface on the CM6700 matrix back plate: one is local keyboard connection interface RJ45 (“LOCAL KEYBOARD”), which can control the single keyboard within the distance of 7.6m;The other is the remote interface RS422 (“REMOTE KEYBOARD(s)”), which can connect with the keyboard RS422 interface, the maximum distance is 1200m.

2. 2. 2 Rs422 remote connection

Rs422 connection line, one end connects with Rs422 interface (REMOTE KEYBOARD(s)) of Cm6700 back plate, the other end connects with Rs422 interface of the keyboard, the keyboard interface Rs422 (R+ R-) corresponds with matrix interface Rs422 (T+ T-) , the keyboard interface Rs422 (T+ T-) corresponds with matrix interface Rs422 (R+ R-) .

Rs422 remote connection, the maximum distance between the keyboard and the matrix is 1200m.

2. 2. 1 RJ45 Local Connection

Please insert one crystal end of RJ45 connection line into the Rj45 interface of the keyboard, and insert the other one into the RJ45 interface (“LOCAL KEYBOARD”) of CM6700 matrix.

1、RJ45 local connection, the distance between the keyboard and the matrix is less than 7.6m.
2、RJ45 interface has 12VAC, It not need other power when the keyboard connect to Cm6700 matrix.

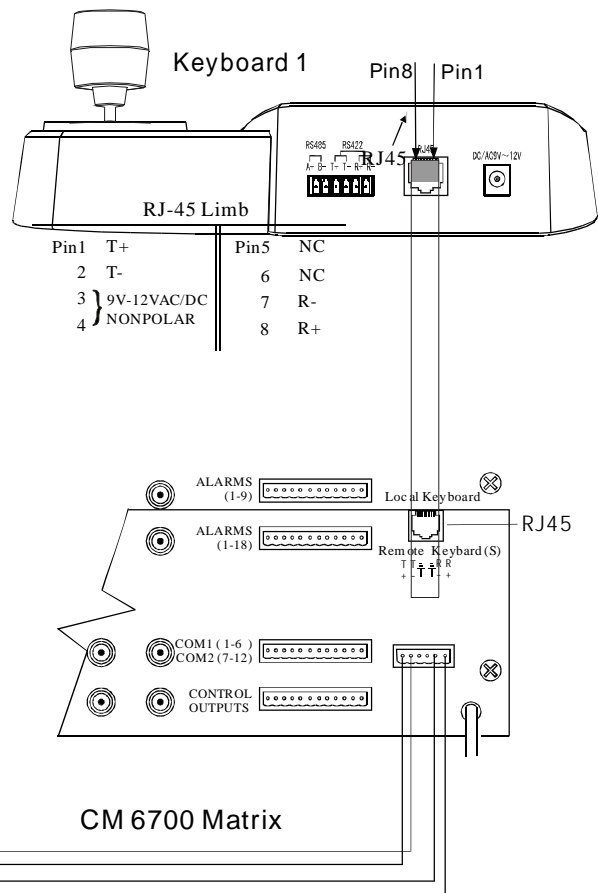
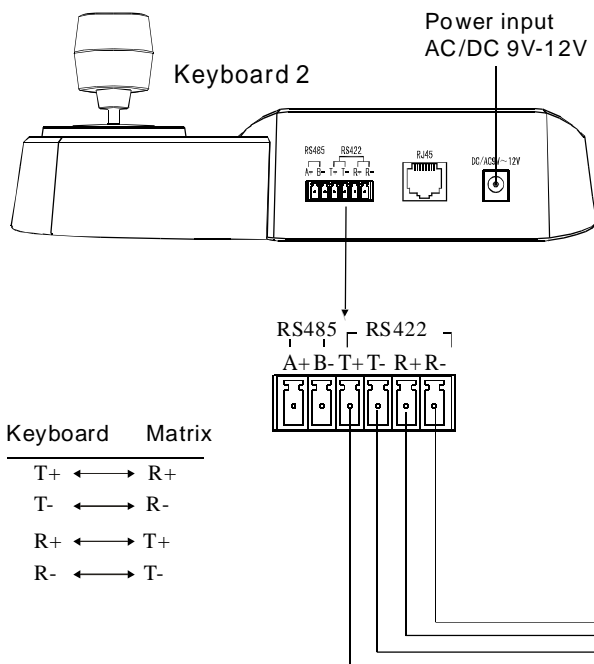

Picture 2-2.1

2.3 Connect with The Dome Directly

You can connect with the dome by Rs485 interface when the keyboard controls the dome directly. The Rs485 interface of the dome is on the switchboard of pendent hanger of the upper cover of the dome. You can find the 4Pin control/power socket and find the corresponding Rs485 (A+, B-) interface according to the above mark when you turn the metal button inside the hanger and open the switchboard.

There are different connection ways according to the domes which produce by the different manufacturers. About connection with the dome, please see to the dome installation manual.

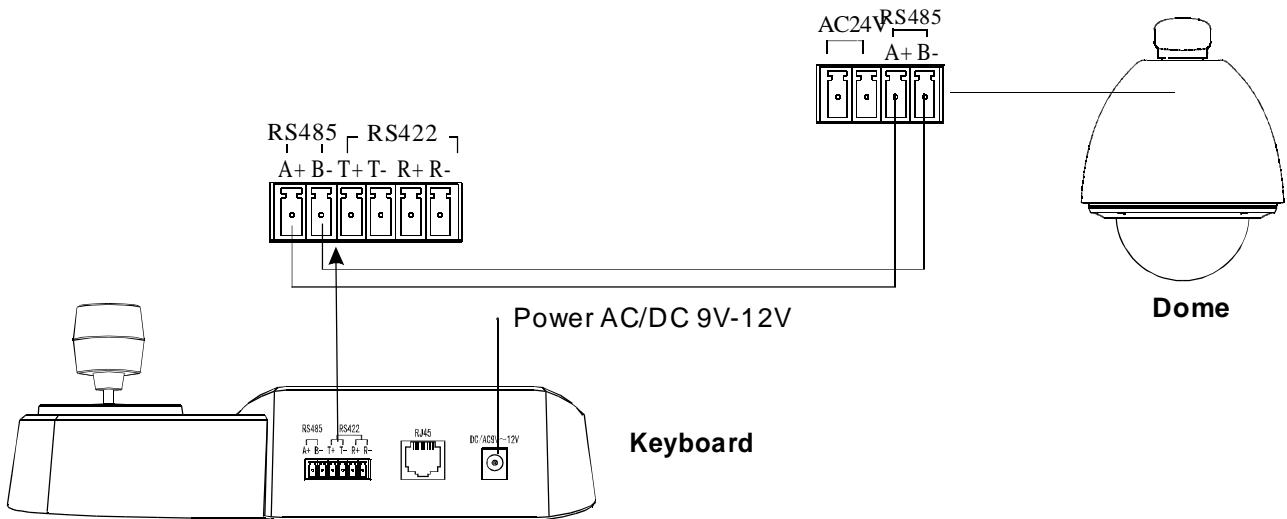

Picture 2-3.1

2. 4 The Connection of The Keyboard in The System

The keyboard controls the matrix and then control the domes indirectly by the matrix (sees to the picture 2.4-1) When unconnect with the matrix, the keyboard controls the dome directly.

Keyboard and camera parallel connect to Rs 485 Bus and each keyboard can control each dome. This way is required to have a main keyboard (the main keyboard ID set as 1), the Baud rate of keyboard is set as 9600bps. (sees to the picture 2.4-2)

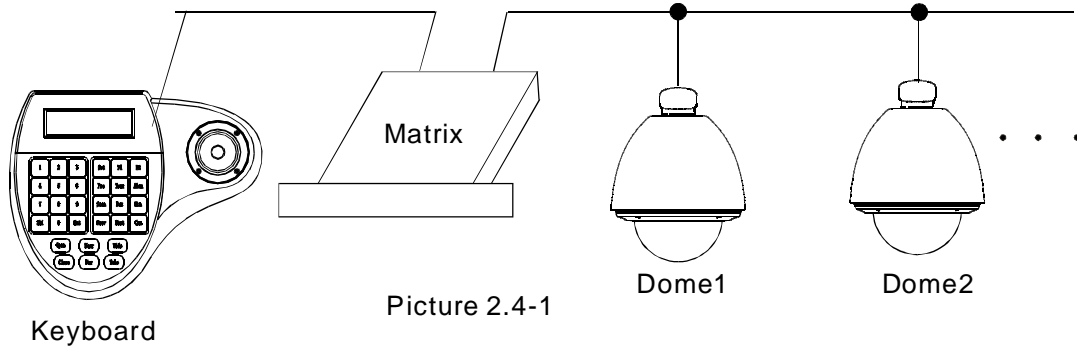

Picture 2.4-1

 **NOTICE**

1. A line of Rs485 may control up to 32 main controlling and under controlling equipments, so a keyboard which controls the dome directly may connect up to 31 domes.
2. The system may connect up to 4 keyboards at the same time, and the four keyboards ID are different.

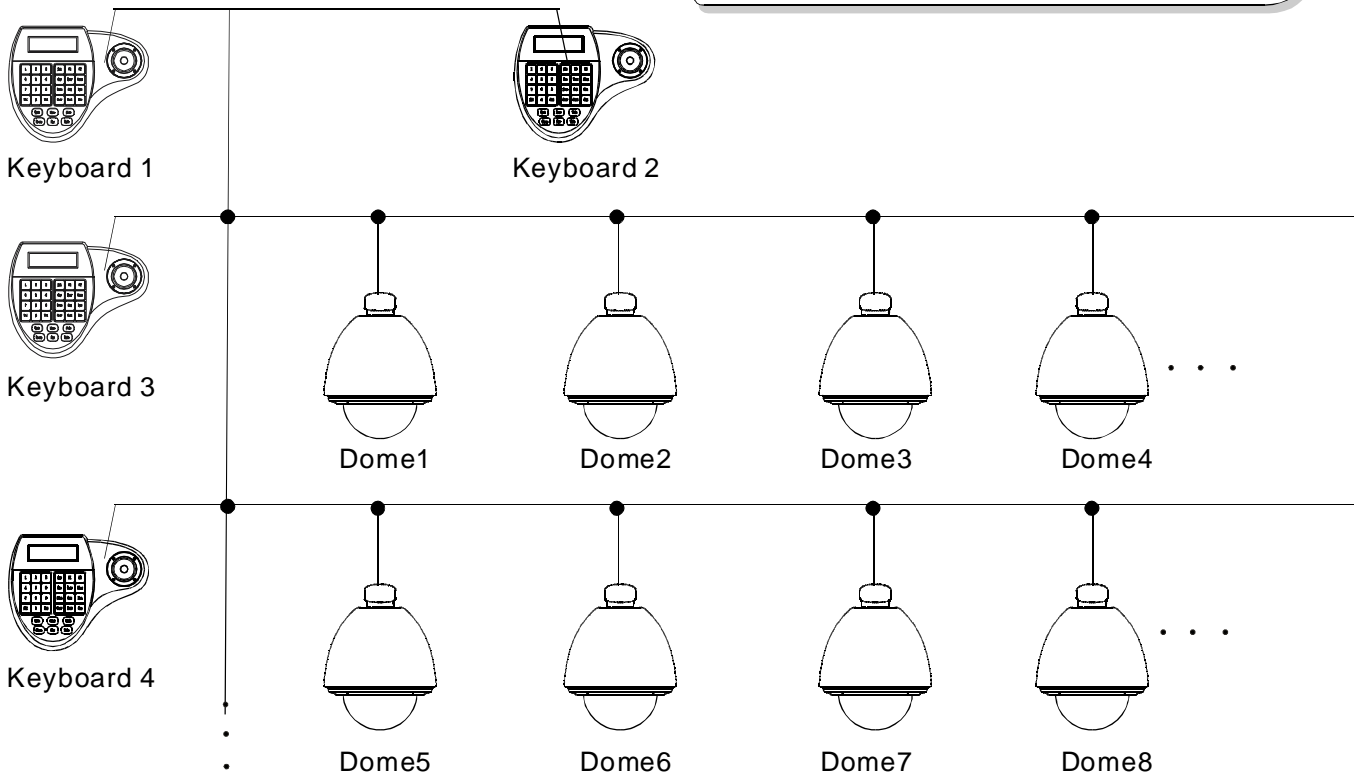

Picture 2.4-2

3. Keyboard Operation Manual

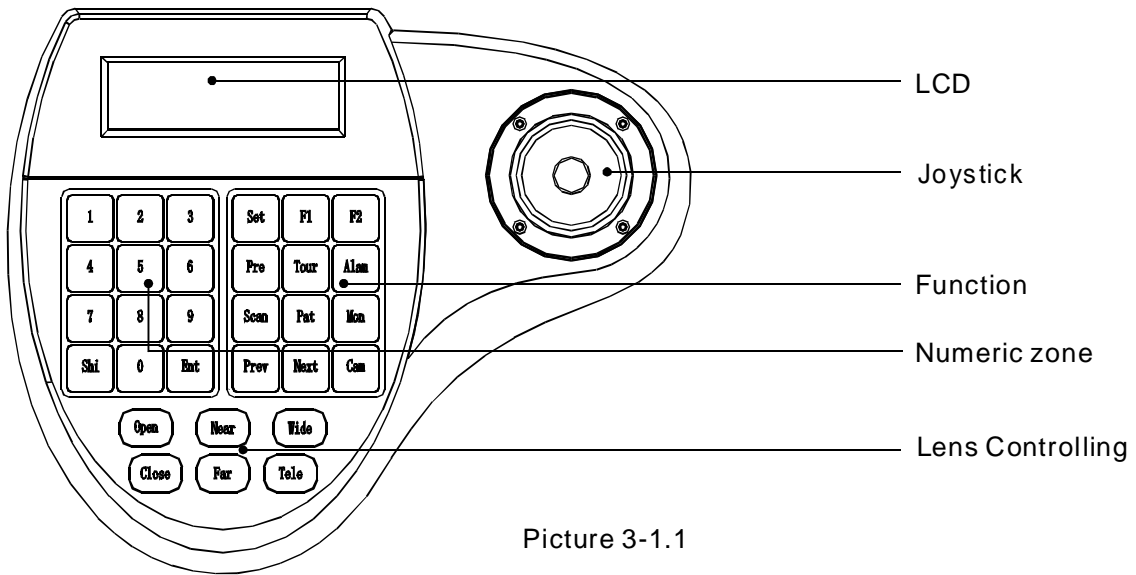

Picture 3-1.1

This paragraph describes mainly the operation ways of keyboard, it needs to especially explain that different systematic platform has not the same operations, and different systematic platform may have some particular requirements and operations, please operate it to combine with the operation manual of dome and matrix.

3.2 LCD

LCD display is used to list the basic information of keyboard operation, which involves controlling camera, monitor ID, baud rate and so on. In the last line there are keyboard input commands and joystick operation. As the right picture shows: When operate it, LCD will turn on back light, in order to operate easily; stop to operate it for 15s, back light will be off automatically.

3.1 Electrify to keyboard

When electrify to keyboard, the keyboard will auto-test the baud rate, protocol and object dome and object monitor will auto-set as 1, and these information will display in the LCD.

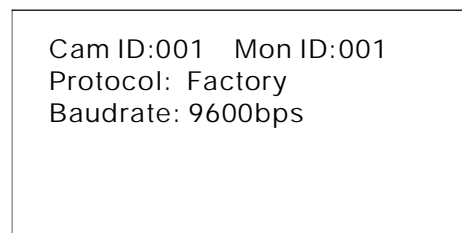

Picture 3-1.2



NOTICE 1. when the keyboard is initializing, the joystick must to return 0, can not to pull or rotate the joystick.

3.3 Joystick controls the dome

Joystick has two functions, one is manually controlling dome rotation, the other is setting controlled object menu.

- Rotate joystick at any directions, the dome will rotate in correspondence with directions, at the same time ,LCD displays the information as lower right corners shows "3 4 5 6", they respectively show tilt up, tilt down, tilt right, tilt left. If the joystick tilts upper right corner, the screen will display such information " $\begin{matrix} 5 \\ 4 \end{matrix}$ " The joystick return to the primary location, and the dome immediately stop to rotate.

- The joystick tilt up means choosing previous menu, which is down means choosing next menu if it is used to set the menu; the joystick is right means entering the next menu or reserving setting after set, which is left means exit or stop reserving.

- More pan/tilt to joystick, the more fast speed the dome rotates. Control the pan/tilt to joystick, it can control the rotation speed of dome.

3.4 Change object dome

【N】 + 【Cam】

【N】 means numeric key (Do not explain it again), input the dome ID. Press **【Cam】** to change object dome.

3.5 Dome lens control

- **Zoom control:**

Press **【TELE】**, lens zoom tele (the multiple of lens increase), leave to stop.

Press **【WIDE】**, lens zoom wide (the multiple of lens reduction), leave to stop.

- **Focus control:**

Press **【FAR】** manually far focus, to make the far object more legible, leave to stop.

Press **【NEAR】** manually near focus, to make the near object more legible, leave to stop.

As usually, the camera is in the status of auto focus, user operate manual focus and run other operations by the two keys, and the camera will automatically resume to auto-focus.

- **Iris control:**

Press **【OPEN】** manual Iris increase, Iris is max, the screen will show white, leave to stop.

Press **【CLOSE】** manual Iris reduction, Iris is min, the screen will show black, leave to stop.

3.6 Dome function operation

3.6.1 Preset

- Set preset: **【SET】 + 【N】 + 【Preset】**

- Call preset: **【N】 + 【Preset】**

【N】 means preset number.

3.6.2 Scan

- Set left limit: **【SET】 + 【1】 + 【Scan】**

- Set right limit: **【SET】 + 【2】 + 【Scan】**

- Run scan: **【1】 + 【Scan】**

User should enter into menu setup if change the speed of scan.

3.6.3 Pattern

- **Set pattern path:** **【SET】 + 【N】 + 【PATTERN】 + Path + 【SET】 + 【0】 + 【PATTERN】**

Press **【SET】**, input pattern NO. (1-4),

Press **【PATTERN】** to enter tour setup, the dome records a series of motions, when end up, press **【SET】**, then press **【0】**, then press **【PATTERN】**, the pattern setup finish.

- **Run pattern:** **【N】 + 【PATTERN】** Input pattern number (1-4), press **【PATTERN】**, run pattern.

3.6.4 Tour

Run tour: **【N】** + **【TOUR】** / **【TOUR】**

Press tour number, press **【TOUR】** , run tour.

If system has only a tour, press **【TOUR】** directly.

Set tour must enter setup menu.

3.8.4 Change object monitor

【N】 + **【MON】**

Input the monitor ID, then press **【MON】** , the image and the menu of the dome that you controlled by keyboard will display in the object monitor.

3.7 Call the dome main menu

【9】 + **【5】** + **【Preset】** : input 95, then press

【Preset】 to call the main menu of object dome, and the menu is displayed in the object monitor.

How to set the dome menu by keyboard,

Please refer to the dome Operation manual.

3.8 Control the matrix

3.8.1 Switch the domes in order

The matrix connects sixteen domes, and switches the dome to previous and next dome. The LCD will display NO, date and time.

【PREV】 : switch to previous dome. Press

【PREV】 , switch to previous dome in single step; Press **【PREV】** to hold it for 2s, and jump sixteen domes of the connection matrix in previous order.

Press **【Stop】** to stop to switch.

【NEXT】 :switch to next dome. Press **【NEXT】** to switch the next dome in single step; press **【NEXT】** to hold it for 2s, and jump the sixteen domes of the connection matrix.

【Stop】 : switch continuously, press **【Stop】** to stop to switch.

3.8.2 Call main menu of matrix

【Shift】 + **【Set】** : call the main menu, and the menu will be displayed in the object monitor. How to set the matrix menu by keyboard? Please refer to the matrix operation manual.

3.8.3 Confirm after program

【ENTER】 : after the matrix programmed, press **【ENTER】** , means confirm after program, as for the detail program, please refer to the matrix operation manual.

4、 The Keyboard Menu Controlling

* The keyboard menu controlling

Press **【SET】** ,keep 2 seconds; Got the main menu, the LCD display is following .(See the picture 4.1-1)all menu setup should call main menu.

Press numerical key or move the joystick up and down to the option which you need and then turn it right after entering the main menu, which can enter the relevant menu setting.

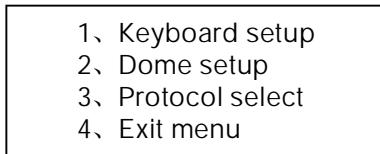

Picture 4.1-1

* Saving Setting

Choose relevant numerical keys in according to the menu hint, then can enter relevant function setting; Press **【Enter】** to reserve; LCD will display “success” after finishing the setting successfully.

* Return to Previous menu

Press **【Prev】** ,or move the joystick leftwards, then return the previous menu.

4.1 Keyboard Parameter Setting

4.1.1 Set keyboard ID

1. Enter main menu,LCD display (See to picture 4.1.1-1)

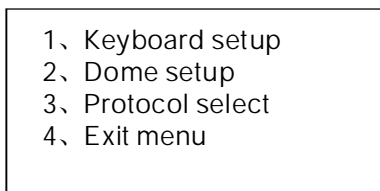

Picture 4.1.1-1

2. Press **【1】** then choose keyboard setting

LCD display (See to the picture 4.1.1-2)

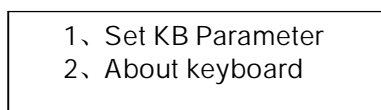

Picture 4.1.1-2

3. Press **【1】** to choose keyboard Specification

LCD display (Sees to the picture 4.1.1-3)

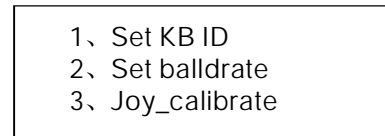

Picture 4.1.1-3

4. Press **【1】** to choose keyboard ID setting

LCD display (Sees to the picture 4.1.1-4)

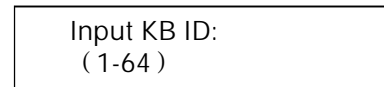

Picture 4.1.1-4

Press the relative numerical key (1-64) ; press enter **【 Enter 】** to confirm. The screen display (See to picture 4.1.1-5), which means operating successfully.

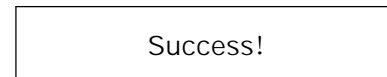

Picture 4.1.1-5

The screen will show **【 Error 】** if input the numerical key which are excess the ID scope (1-64) (Sees to picture 4.1.1-6)

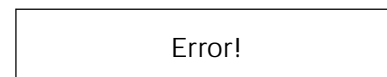

Picture 4.1.1-6

5. Press **【PREV】** or move the joystick leftwards then go back gradually



NOTICE

The factory default ID of the keyboard is 1; The ID Number must be 1 if the single keyboard works; It can connect up to 4 keyboard when working on line, but make sure there is only a keyboard ID set as 1, otherwise all the online keyboards can not work normally.

4.1.2 The keyboard baud rate setting

Enter menu (LCD display sees to the picture 4.1.1-1)

Press **【1】** to set the keyboard

LCD display (sees to the picture 4.1.1-2)

Press **【2】** to set the keyboard baud rate.

LCD display (Sees to the picture 4.1.2-1)

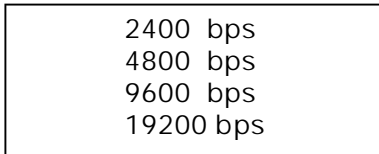

Picture 4.1.2-1

The baud rate is divided into 2400bps,4800bps, 9600bps and 19200bps,user can choose baud rate according to the application and then press **【Enter】** to save. The screen display **success** It means the operation is **success**. Then Press **【Prev】** or move the joystick leftwards to go back.



NOTICE

Must be used 9600BPS when connecting with the matrix; and must be used 9600BPS or 19200bps when connecting the keyboard online.

4.1.3 Joystick Calibration

User enter into the Joystick calibration menu and calibrate the joystick when it can not be controlled.

The joystick must be nature state when you do it.

Enter the main menu.

LCD display.(sees to the picture 4.1.1-1)

Press **【1】** to choose the keyboard setting.

LCD display. (sees to the picture 4.1.1-3)

Press **【3】** to enter Joystick Calibration.

LCD display (sees to the picture 4.1.3-1)



Picture 4.1.3-1

Press **【Enter】** then finish the operation
The screen display (sees to the picture 4.1.3-2)

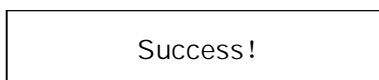

Picture 4.1.3-2



NOTICE

The joystick must be nature state when joystick calibration.

4.1.4 Multi-keyboard Connection state setting

Enter into OSD menu, LCD will display as Picture 4.1.1-1 shows.

Press **【1】** to set the keyboard.

LCD will display as Picture 4.1.1-2 shows.

Press **【4】** to set multi-keyboard connection state setting.After you select **【Multi keyboard state】**, tilt up/down the joystick to set the state as "ON" or "OFF", the default setting of keyboard is OFF, as it set as ON, it can support multi-keyboard work, there is non-interference between them, one group can support 4pcs keyboard mostly, as Multi-keyboard state is opened, if there is only a keyboard to work, the keyboard address must be set as 1, or the keyboard can't be controlled.



NOTICE

In multi-keyboard state the baud rateof each keyboard should be set as 9600bps.

4.1.5 Keyboard message display

Enter the main menu

Press **【2】** to check the keyboard message

LCD display (sees to the picture 4.1.4-1)

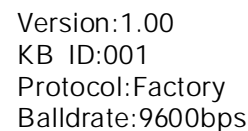

Version:1.00
KB ID:001
Protocol:Factory
Balldrate:9600bps

Picture 4.1.4-1

Press **【Prev】** or move the joystick leftwards to return. The keyboard message menu will display the keyboard parameter setting, the keyboard model, ID address, the Keyboard protocol and the keyboard baud rate.

4. 2 Dome setting

This paragraph mainly describes main functions of the operation ways of keyboard, it needs to especially explain that different systematic platform has not the same operations, and different systematic platform may have some particular requirements and operations, please operate it to combine with the operation manual of dome and matrix.

4.2.1 Dome preset setting

Enter the main menu, as LCD shows (Picture 4.1.1-1)

Press **【2】** to enter dome setting menu, as LCD shows (Picture 4.2.1-1); move joystick up and down to separately set dome preset, scan, pattern and tour.

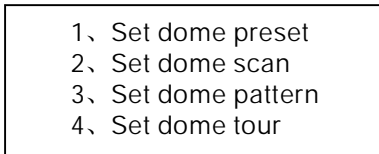

Picture 4.2.1-1

Press **【1】** to enter dome preset setting, as LCD shows (Picture 4.2.1-1)

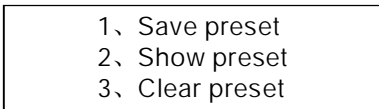

Picture 4.2.1-2

The first item is setting dome preset; the second item is calling dome preset; the third item is clearing dome preset.

Choosing **【1】** to enter preset setting, this item requires inputting the preset number that you will save, as LCD shows (Picture 4.2.1-3)

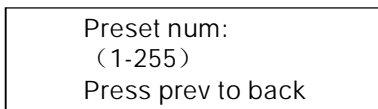

Picture 4.2.1-3

After entering the setting dome preset menu, the joystick will control the dome directly, inputting the corresponding preset number, then press **【Enter】** to save, LCD will show **(Success)**. As picture 4.2.1-4 shows.

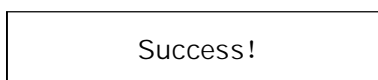

Picture 4.2.1-4

Press **【Prev】** to back to the former menu.

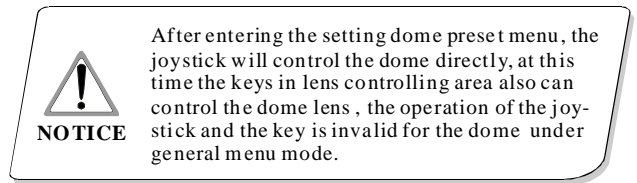

4.2.2 Dome scan setting

Pre **【2】** to enter the calling preset menu, As LCD shows (Picture 4.2.1-5)

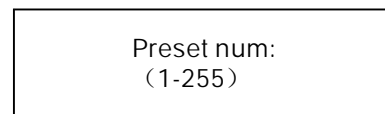

Picture 4.2.1-5

Input corresponding preset number, press **【Enter】** to call preset, LCD will show **(Success)** tilt the joystick left or press **【Prev】** to back to the former menu.

Press **【3】** to enter the clearing preset menu, As LCD shows (Picture 4.2.1-6)

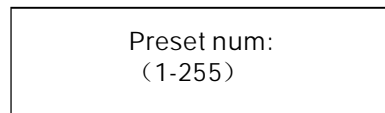

Picture 4.2.1-6

Input the preset number that you want to clear, press **【Enter】** to clear preset, LCD will show **(Success)** and back to the former menu.

Enter the menu, as LCD shows (picture 4.1.1-1)

Press **【2】** to enter the dome setting menu, as LCD shows (picture 4.2.1-1)

Press **【2】** again to enter the dome scan setting menu, as LCD shows (picture 4.2.2-1)

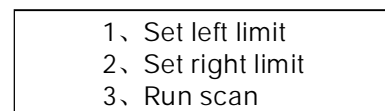

Picture 4.2.2-1

Dome scan setting includes setting dome left limit, right limit and running scan.

Choosing **【1】** to set dome left limit, as LCD shows (picture 4.2.2-2)

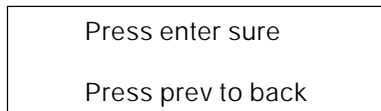

Picture 4.2.2-2

After entering the setting dome limit menu, to move the dome in an appropriate position, then press **【Enter】** to save, LCD will show (**Success**) and back to the former menu.

Choosing the second item (Set right limit), same operation as left limit.

Back to scan menu, then press **【3】** to run scan.

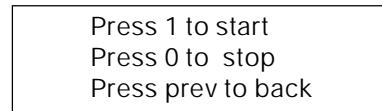
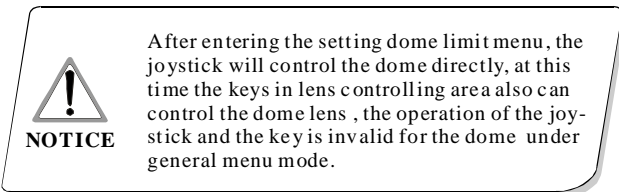

Picture 4.2.3-2

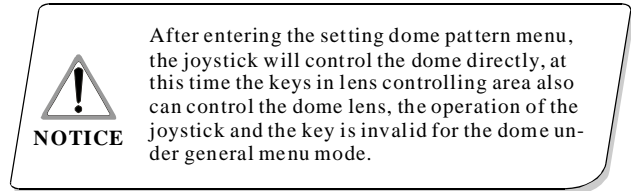

4.2.4 Tour setting

Press **【2】** to enter dome setting menu, as LCD shows (picture 4.2.1-1)

Then Press **【4】** to enter the menu of tour, as LCD shows (picture 4.2.4-1)

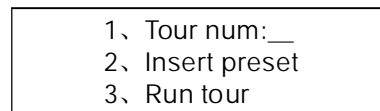

Picture 4.2.4-1

After entering the menu, the system requires inputting tour that you will set in the first item, the input range is 1-6, press **【Enter】** to confirm, the cursor will auto-jump to the second row to start tour setting, if user has finished to set tour already, you can jump over the second item to run tour directly, LCD will show (**Success**) and back to the former menu, it means the operation is successful.

Choosing the second item (as picture 4.2.4-2 shows) to input presets that you need to insert in a tour, inputting preset speed in the second item: Input range 1-127, inputting preset park time in the third item: input range 1-255, press **【Enter】** to confirm, LCD will show (**Success**) and back to the former menu, it means the operation of adding preset is successful.

4.2.3 Pattern setting

Enter the menu, as LCD shows (picture 4.1.1-1)

Press **【2】** to enter the dome setting menu, as LCD shows (Picture 4.2.1-1)

Then Press **【3】** to enter the pattern setting menu, as LCD shows (picture 4.2.3-1)

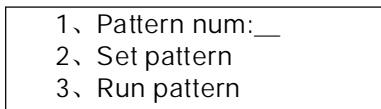

Picture 4.2.3-1

After entering the menu, the system requires inputting pattern tour that you set in the first item, the input range is 1-4, press **【Enter】** to confirm, the cursor will auto-jump to the second item, to start setting pattern, if user has finished to set pattern already, you can jump over this item, and choose **【3】** to run pattern directly.

Pattern setting: after entering the pattern menu, to move the dome in an appropriate position, press **【1】** to start to record pattern tour. LCD will show (**Start.....**) as picture 4.2.3-2 shows.

Press (0) to stop recording pattern, LCD will show (**Success**) and back to the former menu, it means the operation is successful.

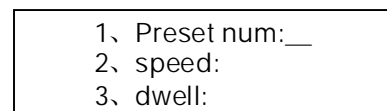

Picture 4.2.4-2

Press **【3】** to run tour.

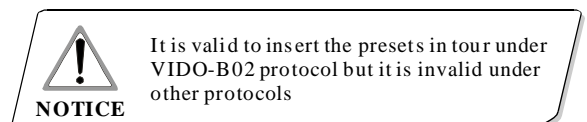

4.3 Protocol setting

Enter the menu, as LCD shows (picture 4.1.1-1)

Press **【3】** to enter protocol setting, as LCD shows (picture 4.3-1)

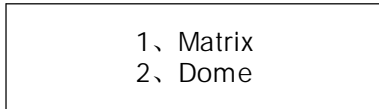

Picture 4.3-1

4.3.1 Pelco matrix mode

Press **【1】** to enter PELCO matrix mode

As LCD shows (picture 4.3.1-1)

Press **【Enter】** to choose protocol and back to the former menu.

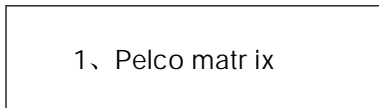

Picture 4.3.1-1

4.3.2 Dome controlling mode

Chose **【2】** to enter dome directly controlling mode, as LCD shows (picture 4.3.2-1)

Choose corresponding protocol according to user's actual instance, the system will back to the former menu automatically after deciding the protocol.

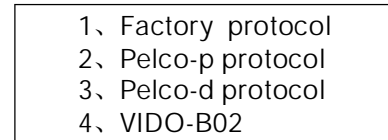

Picture 4.3.2-1

4.4 Exit to keyboard menu

Enter the menu, as LCD shows (picture 4.2.1-1)

Press **【4】** to exit the menu directly.

5. 1 RS485 Bus Basic Knowledge

* Characteristic of RS485 Bus line

According to RS485 standards, RS485 Bus is of half-duplexed data transmission cables with characteristic impedance as $120\ \Omega$. The maximum load capacity is 32 unit loads (including main controller and controller equipment)

* Transmission distance of RS485 Bus line

When user selects the 0.56mm (24AWG) twisted-pair as data transmission cable, the maximum theoretical transmitting distances are as follows according to different baud rate:

If user selects thinner cables, or installs the dome in an environment with strong electromagnetic interference, or connects lots of equipment to the RS485 Bus, the maximum transmitting distance will be decreased. To increase the maximum transmitting distance, do the contrary.

Baud Rate	Maximum Distance
2400bps	1800m
4800bps	1200m
9600bps	800m
19200bps	600m

* Connection and terminal resistance

The Rs485 standards require a daisy-chain connection between the equipment. There must be termination resistance with $120\ \Omega$ at both ends of the connection (refer to picture 4-1.1).

Please refer to picture 4-1.2 for simple connection. And “D” should not exceed 7m.

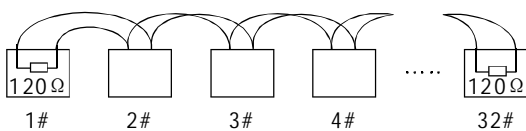

Picture 4-1.1

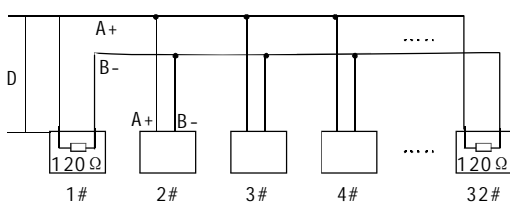

Picture 4-1.2

* Problems in practical use

User adopts a star configuration in practical connection. The termination resistors must be connected to the two equipments which are farthest away from each other, such as equipment 1# and 15# (refer to picture 4-1.3). This connection way not accord with the requirements of Rs485 standards, it is easy to bring signal reflections, lower anti-interference performance when the cable distance of the equipment is far away from each other. The reliability of control signals are decreased. It can not control the dome, or sometimes can or sometimes can not, or continuous operate by itself.

The factory will recommend the Rs485 distributor. The distributor can transfer the star configuration connection to the mode of connection accordance with the Rs485 standards. The new connection achieves reliable data transmission and avoid the problem. (refer to picture 4-1.4)

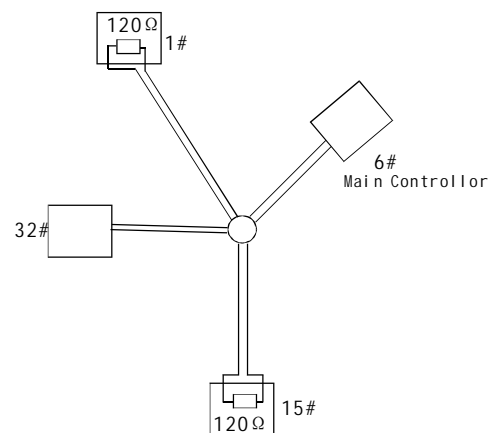

Picture 4-1.3

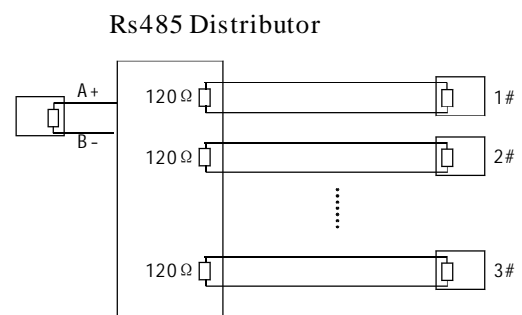

Picture 4-1.4

5.2 Keyboard shortcut operation manual

Working Mode	Shortcut	Operation object	Function
Direct Control Mode and PELCO Matrix Mode	【N】 + 【Cam】	High speed dome	Input Dome ID, press 【Cam】 to select object dome.
	【Tele】	High speed dome	Press 【Tele】 , increase the multiple of lens
	【Wide】	High speed dome	Press 【Wide】 , reduce the multiple of lens
	【Far】	High speed dome	Press 【Far】 , far focus
	【Near】	High speed dome	Press 【Near】 , near focus
	【Close】	High speed dome	Press 【Close】 , reduct the Iris
	【Open】	High speed dome	Press 【Open】 , increase th Iris
	【Set】 + 【N】 + 【Preset】	High speed dome	Adjust the image to object position, press 【Set】 to input preset Number, then press 【Preset】 to set preset.
	【N】 + 【Preset】	High speed dome	Input preset Number, press 【Preset】 to call the preset.
	【SET】 + 【1】 + 【Scan】	High speed dome	Adjust the image to object position, press 【Set】 to input 1, then press 【Scan】 to set scan left limit.
	【SET】 + 【2】 + 【Scan】	High speed dome	Adjust the image to object position, press 【Set】 to input 2, then press 【Scan】 to set scan right limit.
	【1】 + 【Scan】	High speed dome	Input 1, press 【Scan】 to run scan.
	【Set】 + 【N】 + 【Pattern】	High speed dome	Press 【Set】 to input pattern number, press 【Pattern】 to record pattern path.
	【Set】 + 【0】 + 【Pattern】	High speed dome	Press 【Set】 ,input 0, then press 【Pattern】 to save pattern
	【N】 + 【Pattern】	High speed dome	Input pattern number(1-4), press 【Pattern】 to run pattern.
【N】 + 【Tour】 / 【Tour】	High speed dome	Input tour number, press 【Tour】 or directly press 【Tour】 to run cruise.	
【9】 + 【5】 + 【Preset】	High speed dome	Input 95 to call main menu of dome	
PELCO Matrix Mode	【Shift】 + 【Set】	Matrix	Press 【Shift】 and 【Set】 to call main menu of matrix
	【Prev】	Matrix	Switch to previous dome. Press 【Prev】 to jump the previous dome, press 【Prev】 to hold it for 2s, continuously switch the sixteen domes of connection matrix forwards.
	【Next】	Matrix	Switch to next dome. Press 【Next】 to jump the next dome, press 【Next】 to hold it for 2s, continuously switch the sixteen domes of connection matrix backwards.
	【Stop】	Matrix	Stop to switch.
	【Enter】	Matrix	After program, press 【Enter】 to confirm.
	【N】 + 【MON】	Monitor	Input monitor Number, press 【Cam】 to select object monitor.

6、Keyboard Menu Index

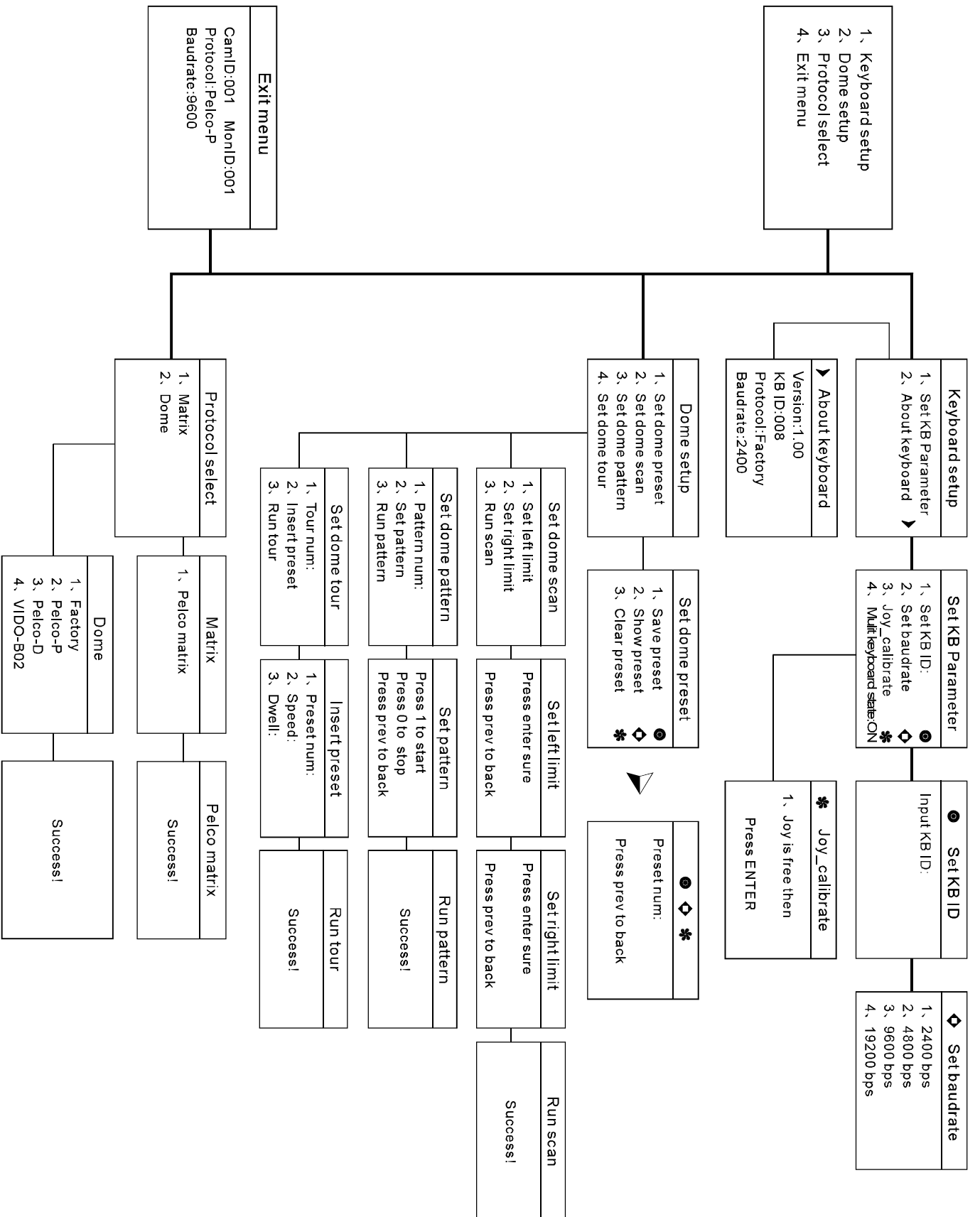

7. Maintenance service terms

1. Range of warranty

- The product will be maintained free for one year.
- The product will be obtained the free maintenance service if the same malfunction appears again within three months.
- Malfunction of products caused by force majeure (such as war, earthquake, lightning strike and so on), abuse, non-standard operation, change of construction, non-normal wear or accident are non-free of warranty.
- Please prevent from the damage which is caused by heavy pressure , the fierce vibration and soaks in the process of transportation and storage, which does not belong to the free maintenance scope.
- Please adopt the way of fission package or original package to transport because the product damage dose not belong to the free maintenance scope if you use the whole packing way , not the original packing way.
- The maintenance services will not be free when the pan/tilt module is disassembled or serviced by the user voluntarily.
- Our company implements the lifetime payable service if the product in malfunction has surpassed the warranty period.
- To the products with defect :if it's in the period of warranty, please fill in the form of warranty information correctly, describe the trouble in details , and provide the trouble in details , and provide original sales invoice or its copy.
- For the damage and loss which was caused by the user's specifically application, factory won't bear any risk and responsibility. The factory compensation made by breach of faith, negligence or tortious won't exceed the amount of the products. The factory won't bear any responsibility for the special, unexpected and continue damage caused by any other reasons.
- Our company has the final right of explanation for the above terms.

2. Warranty terms

- If the products are within the warranty time, the buyer should fill in the warranty card and send back together with the products.

3. Shipping

- If the product needs repaired , you can return it to the manufacturer through the supplier or directly. If you choose the later , please contact us in order to speed up the process. And our company only undertake the one-way freight from manufacturer to customer after maintenance.